

Versa_II - 2 Bay "basic" Rack Kit

Rack Box - 2 Bay Rack

Dimensions and specifications

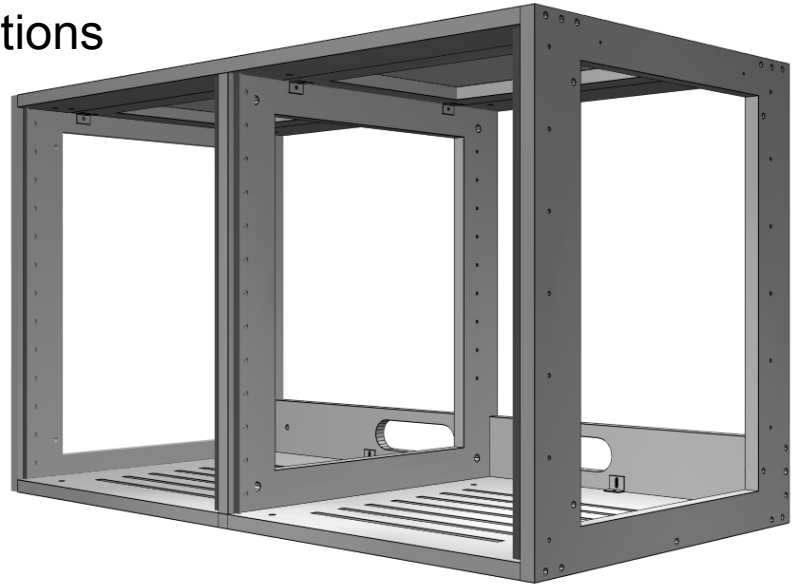
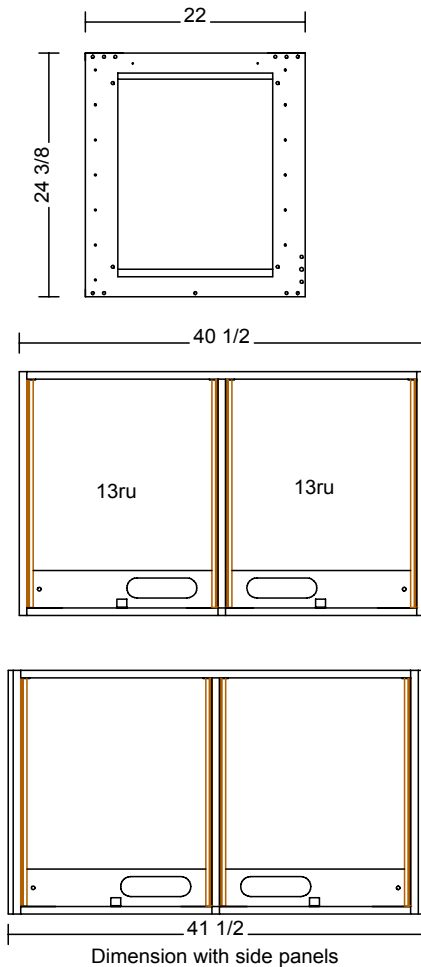

The Versa_II - 2 Bay Rack Kit includes..

- 1) All of the components shown here including the fabric covered top thermal vents.
- 2) (2) (front pair) 13ru rack rail
- 3) Slotted bottom panel for ample air flow.
- 4) Rear Nailer with holes for cable management.
- 5) Steel stiffeners (not shown)
- 6) and the Complete Base Kit (shown below)

Base Kit

The "Base Kit" is included in every rack purchase. It allows you to set up the rack in a variety of configurations.

The parts shown here, and all of the required hardware and instructions are included.

Configuration options are shown on the following page

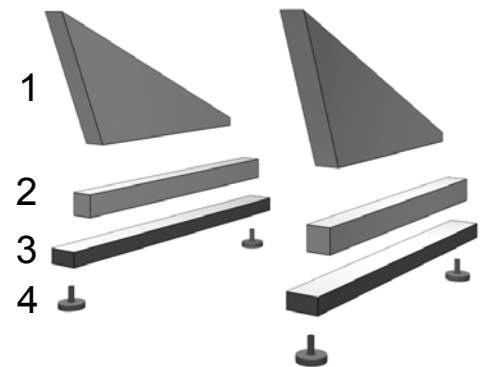

Rack Configurations, options and accessories

Straight

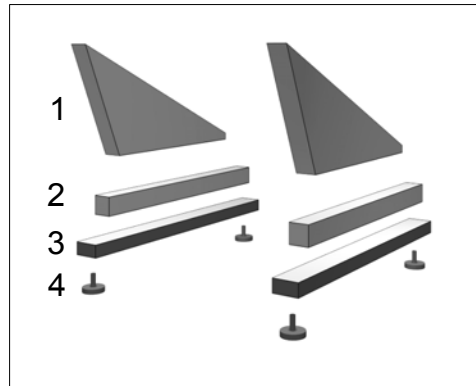
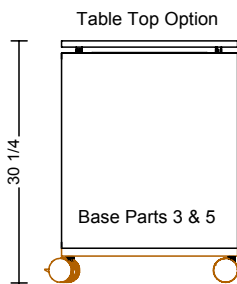
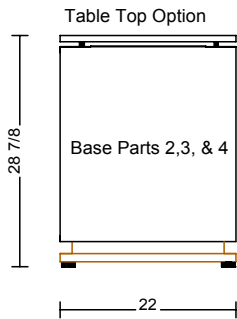
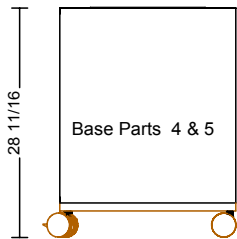
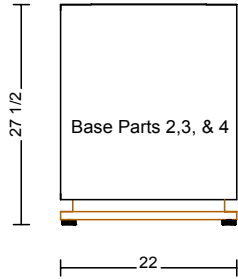

5 Optional Caster Pack

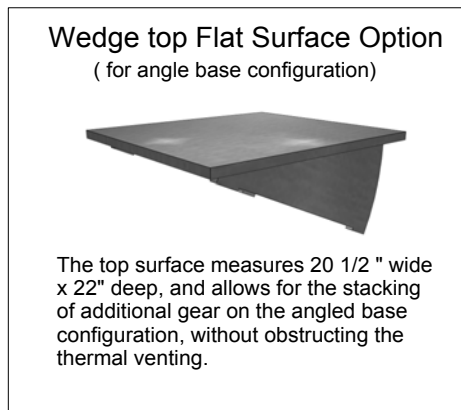
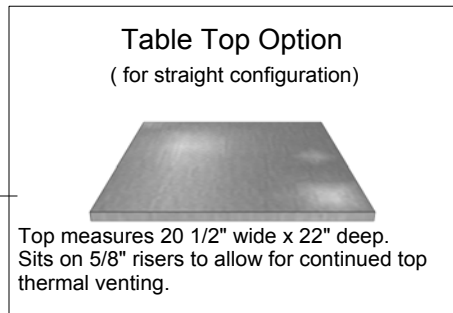

Angled

