

# Face-Up Rack Specifications

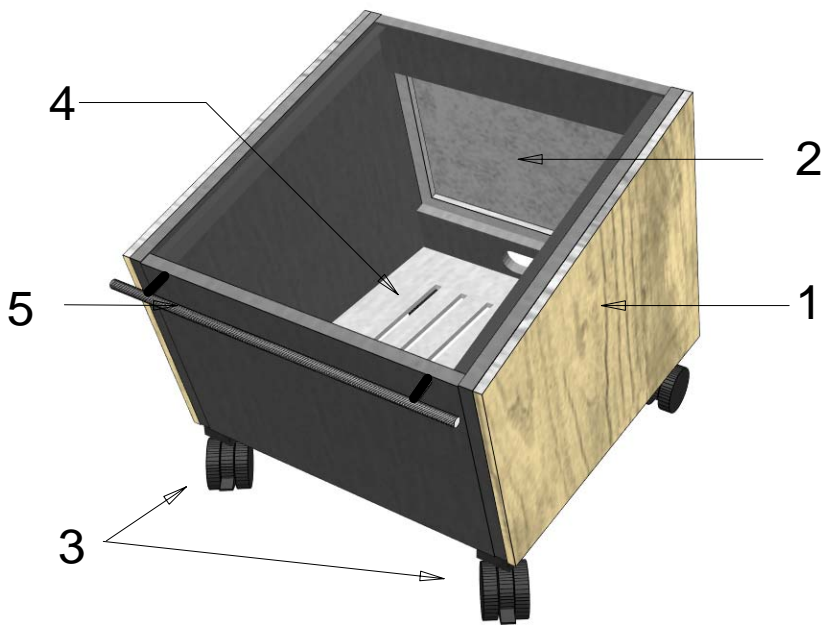

## 6 *New* Bamboo Side Panels



- 1) Black Laminate, Hardwood Veneer, or New (environmentally sustainable) Bamboo side panels (6) .
- 2) Fabric covered rear door provides thermal venting and reduces acoustical reflection.
- 3) 3" rubberized Heavy Duty casters for for easy rolling. The front casters have lever brakes.
- 4) Slotted bottom provides superior thermal venting.
- 5) Full length black handle allows for easy positioning.

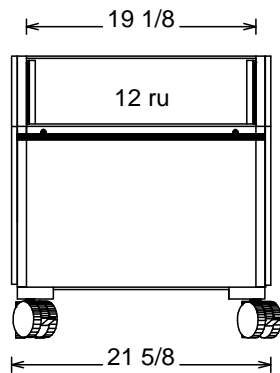

Front View Dimensions

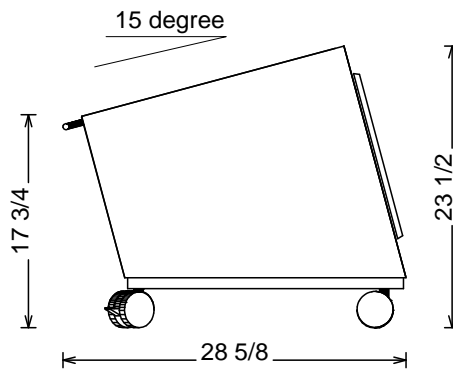

Overall Exterior Dimensions

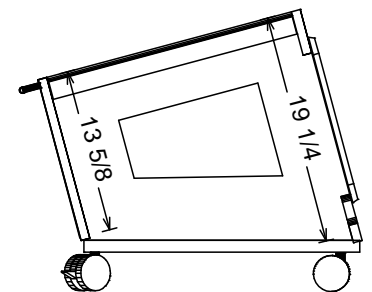

Interior Dimensions