

Versa_II - Basic "2 Bay" Rack Kit

Rack Box - 2 Bay Rack

Dimensions and specifications

The Versa_II - 2 Bay Rack Kit includes...

- 1) Fabric covered top thermal vent panels.
- 2) (2) (front) 13ru rack rail. Rear rail available.
- 3) Slotted bottom panel for ample air flow.
- 4) Rear Nailer with holes for cable management.
- 5) Steel stiffeners (not shown).
- 6) The Complete Base Kit (shown below).

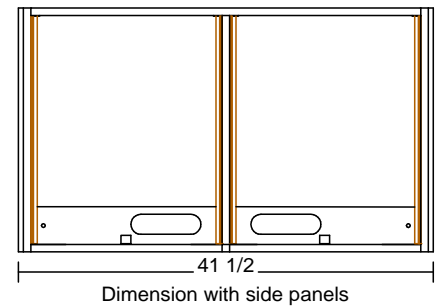
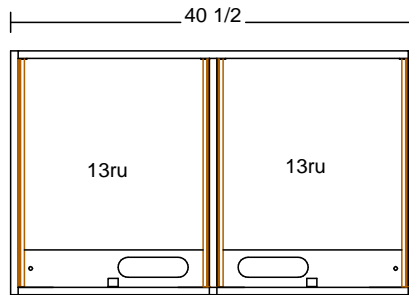
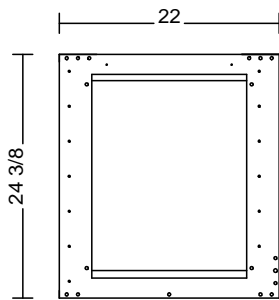
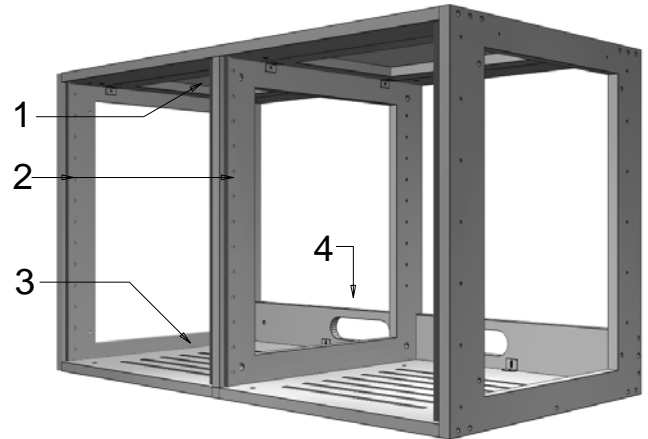

Base Kit

The complete "Base Kit" is included in every rack purchase. It allows you to set up the rack in a variety of configurations. The parts shown here, and all of the required hardware and instructions are included. Configuration options are shown on the following page.

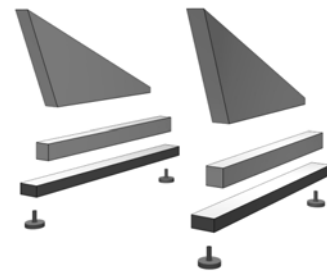

Versa_II Rack Configurations, Options, Accessories and Specifications.

Straight

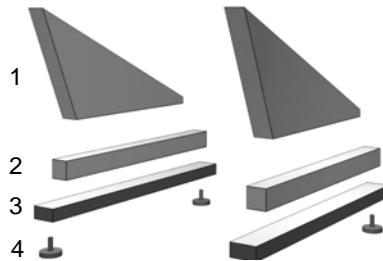
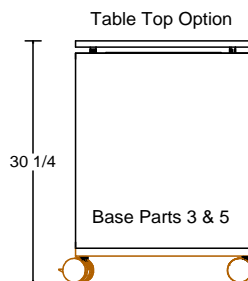
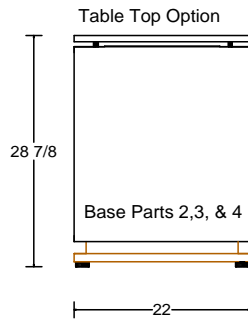
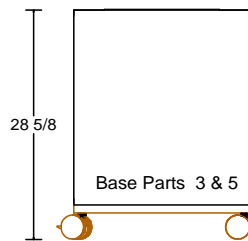
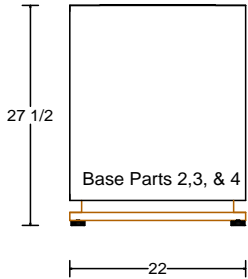

- 1 - 25 degree wedge riser.
- 2 - 1 1/2" straight riser.
- 3 - Steel foot
- 4 - Heavy duty levelers
- 5 - (optional caster pack) Four heavy duty, rubberized casters. Two with brakes for the front.

Angled

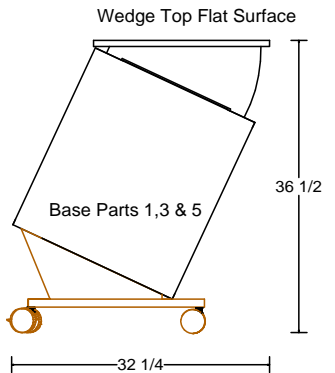
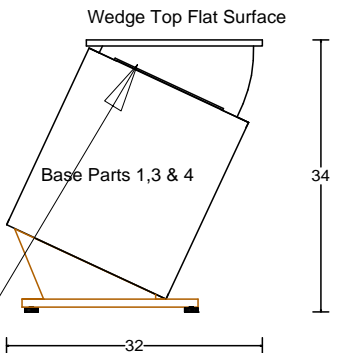
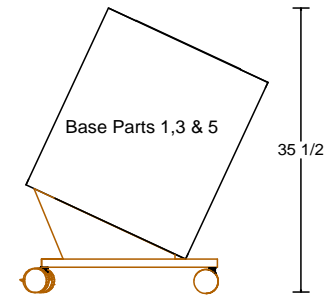
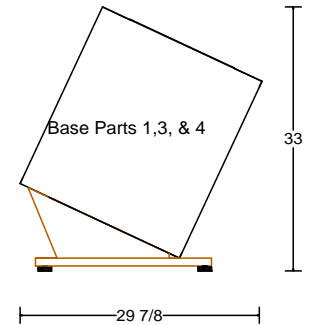
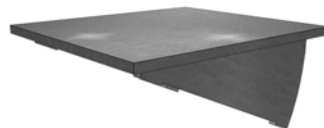

Table Top Option (for straight configuration)



Top measures 20 1/2" wide x 22" deep.
Sits on 5/8" risers to allow for continued top thermal venting.

Wedge top Flat Surface Option (for angle base configuration)



The top surface measures 20 1/2 " wide x 22" deep, and allows for the stacking of additional gear on the angled base configuration, without obstructing the thermal venting.